

SPECTRACOOL
AIR CONDITIONER
N28 MODEL

INSTRUCTION MANUAL

Rev. G

© 2020 nVent

P/N 89115550

89115550



RSPSupply - 1-888-532-2706 - <https://www.RSPSupply.com>
See the product details here

TABLE OF CONTENTS

Warranty and Return Policy.....	2
RECEIVING THE AIR CONDITIONER.....	3
HANDLING AND TESTING THE AIR CONDITIONER.....	3
HOW TO READ MODEL NUMBERS.....	3
For cooling (75-100 F range):.....	4
For heating (55-65 F range):.....	4
TECHNICAL INFORMATION.....	4
Sequence of Operation.....	4
Heating.....	4
Cooling.....	4
Standard and Optional Component Operation.....	4
Thermostat.....	4
Remote Access Control (optional).....	4
Head Pressure Control (optional).....	4
115V/230V to 10V Transformer (optional).....	4
115V/230V to 24V Transformer and Relay (optional).....	4
Schematics and Wiring Diagrams for Thermostat Control.....	5
Generic 115V 1-Phase Schematic (actual unit options may vary).....	5
Generic 230V 1-Phase Schematic (actual unit options may vary).....	5
Generic 460V 1-Phase Schematic (actual unit options may vary).....	6
Generic 115V 1-Phase Wire Diagram (actual unit options may vary).....	7
Generic 230V 1-Phase Wire Diagram (actual unit options may vary).....	8
Generic 460V 1-Phase Wire Diagram (actual unit options may vary).....	9
DIMENSIONAL DRAWING.....	10
With Thermostats.....	10
INSTALLATION INSTRUCTIONS.....	11
REMOTE ACCESS CONTROL (optional).....	12
Introduction.....	12
Energizing The Controller.....	12
Control Status Indication.....	12
Displaying and Changing Program Variables.....	13
OPERATING PARAMETERS.....	13
ALARM PARAMETERS.....	13
Displaying Temperature Sensor #2.....	13
Compressor Restart Time Delay.....	13
Alarm Output Contact.....	13
Alarm Input Connection.....	14
Alarm Condition Display.....	14
Air Conditioner Unit Communication Features.....	14
USB Communication.....	14
Ethernet Communication.....	14
Using the PC Interface Tool.....	15
USB Communication Mode.....	15
Ethernet Communication Mode.....	16
Remote Access Control Pin-out.....	17
Schematics and Wiring Diagrams for Remote Access Control.....	18
Generic 115V 1-Phase Schematic (actual unit options may vary).....	18
Generic 230V 1-Phase Schematic (actual unit options may vary).....	18
Generic 460V 1-Phase Schematic (actual unit options may vary).....	19
Generic 115V 1-Phase Wire Diagram for Remote Access Control (actual unit options may vary).....	20
Generic 230V 1-Phase Wire Diagram for Remote Access Control (actual unit options may vary).....	21
Generic 460V 1-Phase Wire Diagram for Remote Access Control (actual unit options may vary).....	22
DIMENSIONAL DRAWING.....	23
With Remote Access Control.....	23
INSTALLATION INSTRUCTIONS WITH REMOTE ACCESS CONTROL.....	24
MAINTENANCE.....	25
Compressor.....	25
Inlet Air Filter.....	25
How To Remove, Clean or Install a New Inlet Air Filter.....	25
Condenser and Evaporator Air Movers.....	26
Refrigerant Loss.....	26
Refrigerant Properties Chart (R134a).....	26
Unit Characteristics.....	27
Functional Data.....	27
SERVICE DATA.....	28
Components List.....	28
N280416GXXX Pressure Tables.....	29
N280426GXXX Pressure Tables.....	30
N280446GXXX Pressure Tables.....	31
F-GAS INFORMATION.....	31
TROUBLE SHOOTING.....	32
Basic Air Conditioning Trouble Shooting Check List - Thermostat Version.....	32
Symptoms and Possible Causes - Thermostat Version.....	33
Basic Air Conditioning Trouble Shooting Check List - Remote Access Control Version.....	34
Symptoms and Possible Causes - Remote Access Control Version.....	35

NOTE: Some of the information in this manual may not apply if a special unit was ordered. If additional drawings for a special unit are necessary, they have been inserted. Contact Pentair Equipment Protection if further information is required.

WARRANTY AND RETURN POLICY

<https://hoffman.nvent.com/en/hoffman/warranty-information>

RECEIVING THE AIR CONDITIONER

Inspect the air conditioner. Check for concealed damage that may have occurred during shipment. Look for dents, scratches, loose assemblies, evidence of oil, etc. Damage evident upon receipt should be noted on the freight bill. Damage should be brought to the attention of the delivering carrier – NOT to nVent Equipment Protection – within 15 days of delivery. Save the carton and packing material and request an inspection. Then file a claim with the delivering carrier.

nVent Equipment Protection cannot accept responsibility for freight damages; however, we will assist you in any way possible.

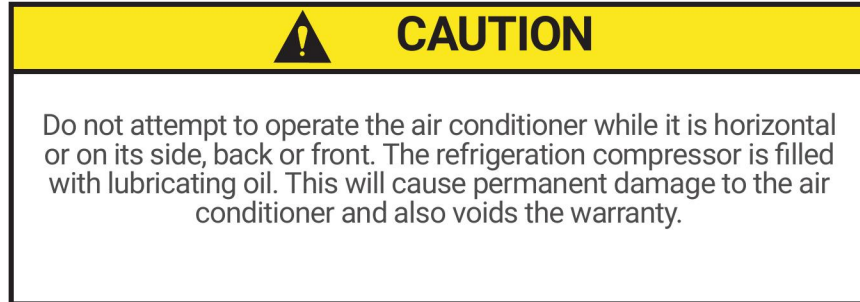

HANDLING AND TESTING THE AIR CONDITIONER

If the air conditioner has been in a horizontal position, be certain it is placed in an upright, vertical or mounting position for a minimum of five (5) minutes before operating.

TEST FOR FUNCTIONALITY BEFORE MOUNTING THE AIR CONDITIONER TO THE ENCLOSURE.

Refer to the nameplate for proper electrical current requirements, and then wire the unit to a properly grounded power supply using copper conductors only. Power supply wiring should be restrained after field installation to ensure no contact with internal fan. Minimum circuit ampacity should be at least 125% of the amperage shown on the unit nameplate. No other equipment should be connected to this circuit to prevent overloading

Immediately after applying power, the evaporator blower (enclosure air) should start running. Operate the air conditioner with the compressor running for five (5) to ten (10) minutes. You will need to set the cooling thermostat or controller setpoint below the ambient temperature to operate the compressor.

Condenser air temperatures should be warmer than normal room temperatures within a few minutes after the condenser impellers start.

See Sequence of Operation on page 4 for specifics on how the unit operates when powered up.

HOW TO READ MODEL NUMBERS

N28	04	2	6	G150
1	2	3	4	5

1. Identifies the type/family of air conditioner and the approximate height (i.e. G28 = Global family about 28 inch high).
2. This is the air conditioner's listed capacity in BTU/Hr. at rated conditions. (i.e. 06=6,000 BTU/Hr. at 131/131 F)
3. 1 = 115 Volt, 2 = 230 Volt, 4 = 460 Volt.
4. 6 = 50/60 Hz or 60 Hz only.
5. Unique set of numbers for each air conditioner which identifies the accessories on a model.

TECHNICAL INFORMATION

SEQUENCE OF OPERATION

The air conditioner comes standard with two internally mounted thermostats or remote access control. There are two modes of operation; heating and cooling. During heating and cooling modes the evaporator fan will be running.

HEATING

When the enclosure temperature is below the heating thermostat setpoint, power is applied to the heaters. When the enclosure temperature is 10 degrees above the setpoint the heater is powered off.

COOLING

When the enclosure temperature is above the cooling thermostat setpoint, power is applied through the thermostat. The compressor is then energized either directly or through a contactor if unit requires one. The condenser impellers will start immediately if the unit is not equipped with an optional head pressure control switch. If the unit is equipped with an optional head pressure control switch, the condenser impellers will start once the refrigerant pressure reaches the setting of the switch. Component specific information is listed below.

Operating the air conditioner below the minimum ambient temperature or above the maximum ambient temperatures indicated on the nameplate voids all warranties. DO NOT set the enclosure thermostat to a temperature lower than 70 F. Doing so can increase the likelihood of frost buildup on the evaporator coil.

The moisture that the enclosure air can contain is limited. If moisture flows from the drain tube continuously this can only mean that ambient air is entering the enclosure. Be aware that frequent opening of the enclosure's door admits humid air that the air conditioner must then dehumidify.

STANDARD AND OPTIONAL COMPONENT OPERATION

THERMOSTAT

The standard G28 air conditioner uses our standard 10-1061-16 thermostat. The thermostat setpoint equals the temperature that the air conditioner turns off. The thermostat has a 10 F differential from setpoint until it calls for cooling or heating. An example of operation is shown below.

FOR COOLING (75-100 F RANGE):

- Thermostat setpoint = 80 F
- Cooling turns on at 90 F
- Cooling turns off at 80 F

FOR HEATING (55-65 F RANGE):

- Thermostat setpoint = 55 F
- Heating turns on at 55 F
- Heating turns off at 65 F

NOTE: For testing purposes only, the thermostat stop screw may be removed (on units so equipped) to allow settings below 70 F. After testing, replace the stop screw and verify that the thermostat cannot be set below 70 F. Extended operation below 70 F can cause coil freeze ups resulting in reduced load and/or unit damage.

REMOTE ACCESS CONTROL (OPTIONAL)

See REMOTE ACCESS CONTROL (optional) on page 12

HEAD PRESSURE CONTROL (OPTIONAL)

Unit is set at the factory, no adjustment necessary.

At a saturated condenser temperature of 82 F (95 psig), the condenser fans will power off. At a saturated condenser temperature of 105 F (165 psig), the condenser fans will power on.

115V/230V TO 10V TRANSFORMER (OPTIONAL)

This transformer powers the thermal display on thermostat controlled units only.

115V/230V TO 24V TRANSFORMER AND RELAY (OPTIONAL)

The transformer and relay are used to operate the condenser blower and compressor by using a customer supplied, remote mounted door switch. This is not a safety door switch, but rather, only helps to reduce condensation at the evaporator coil if the door is opened. The unit will remain electrified when the door switch is operated with the evaporator fan continuing to operate, and potentially, if temperatures are low enough, the heater may continue to operate on outdoor models.

SCHEMATICS AND WIRING DIAGRAMS FOR THERMOSTAT CONTROL

GENERIC 115V 1-PHASE SCHEMATIC (ACTUAL UNIT OPTIONS MAY VARY)

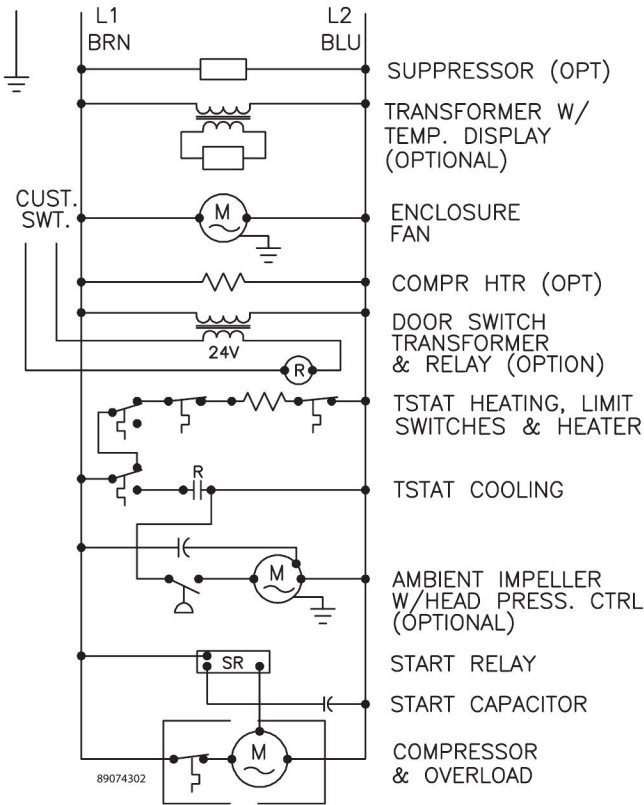

GENERIC 230V 1-PHASE SCHEMATIC (ACTUAL UNIT OPTIONS MAY VARY)

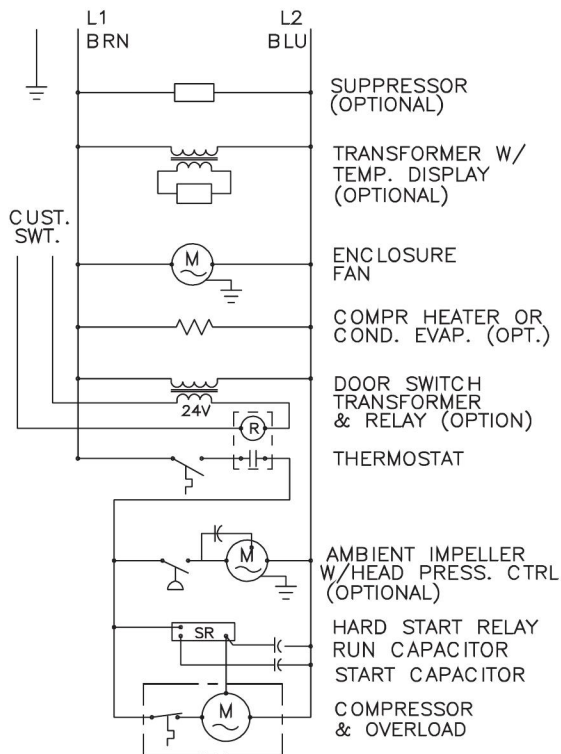

ELECTRICAL SCHEMATIC

89115045 REV A

GENERIC 460V 1-PHASE SCHEMATIC (ACTUAL UNIT OPTIONS MAY VARY)

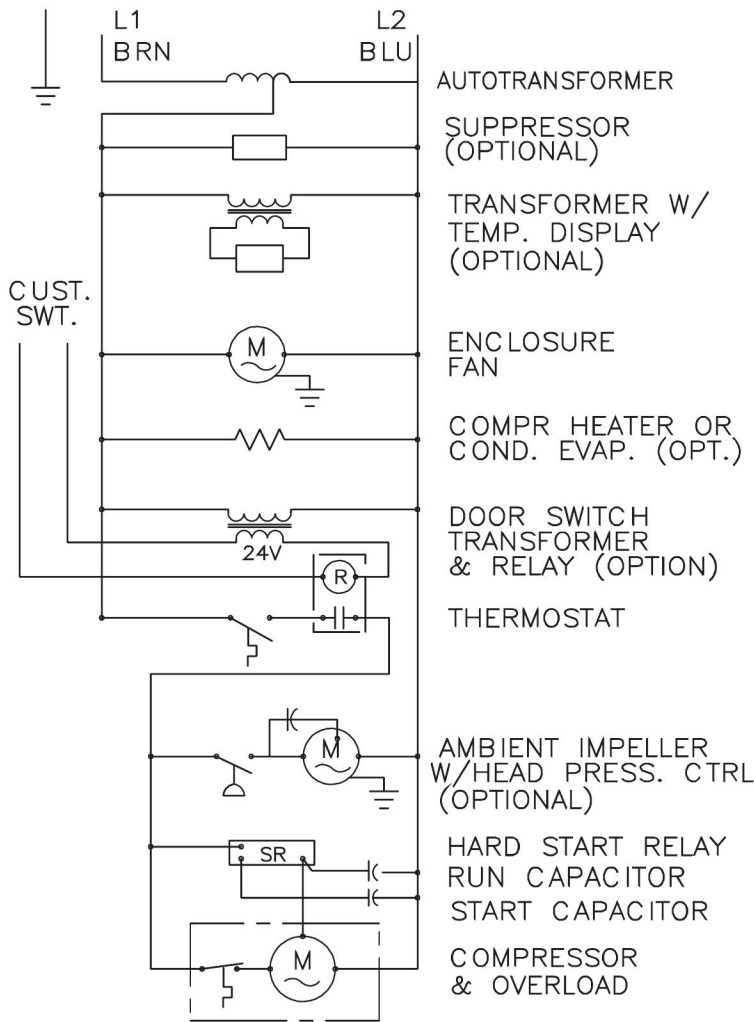

ELECTRICAL SCHEMATIC

89115549 REV A

GENERIC 115V 1-PHASE WIRE DIAGRAM (ACTUAL UNIT OPTIONS MAY VARY)

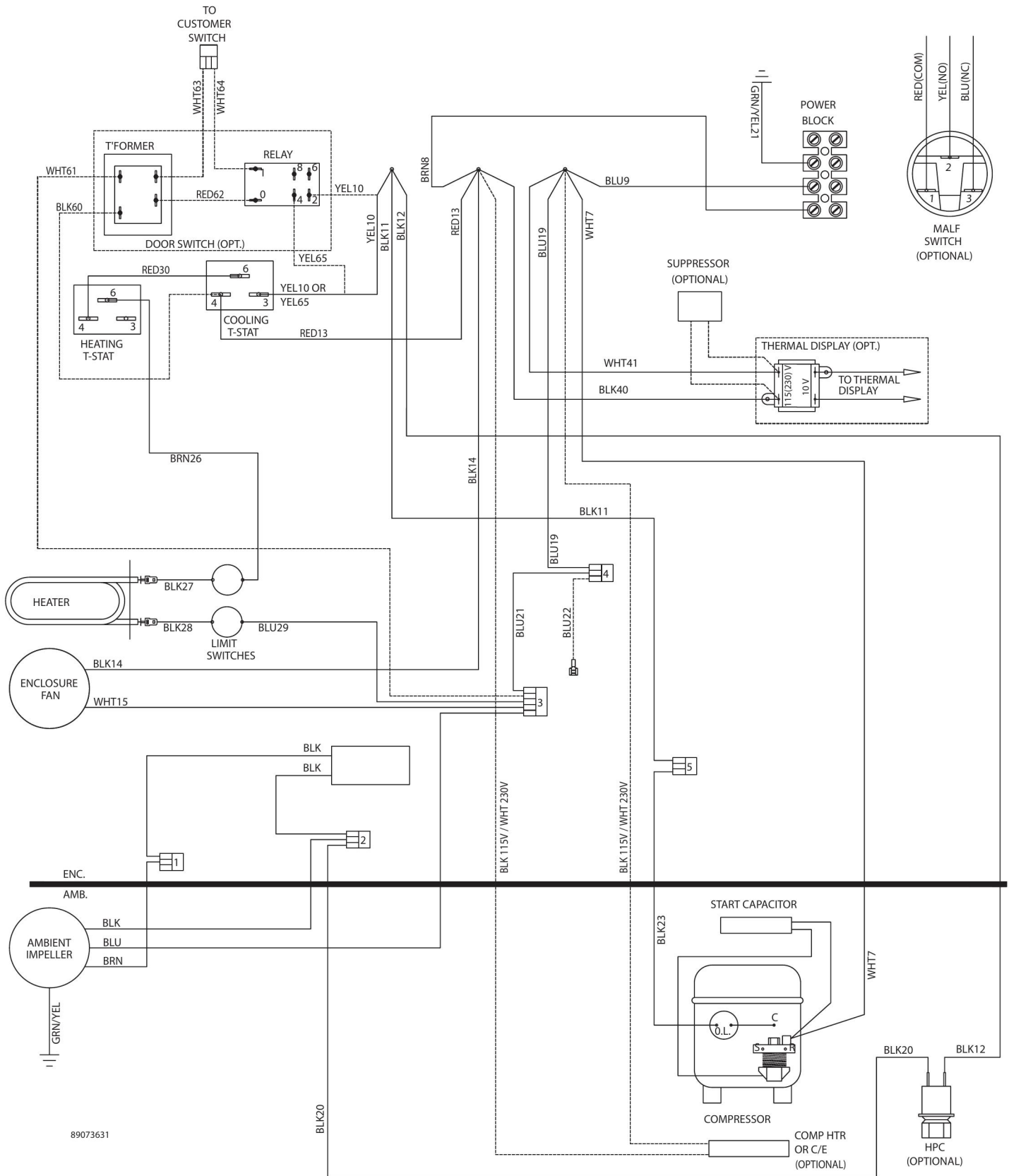

89073631

GENERIC 230V 1-PHASE WIRE DIAGRAM (ACTUAL UNIT OPTIONS MAY VARY)

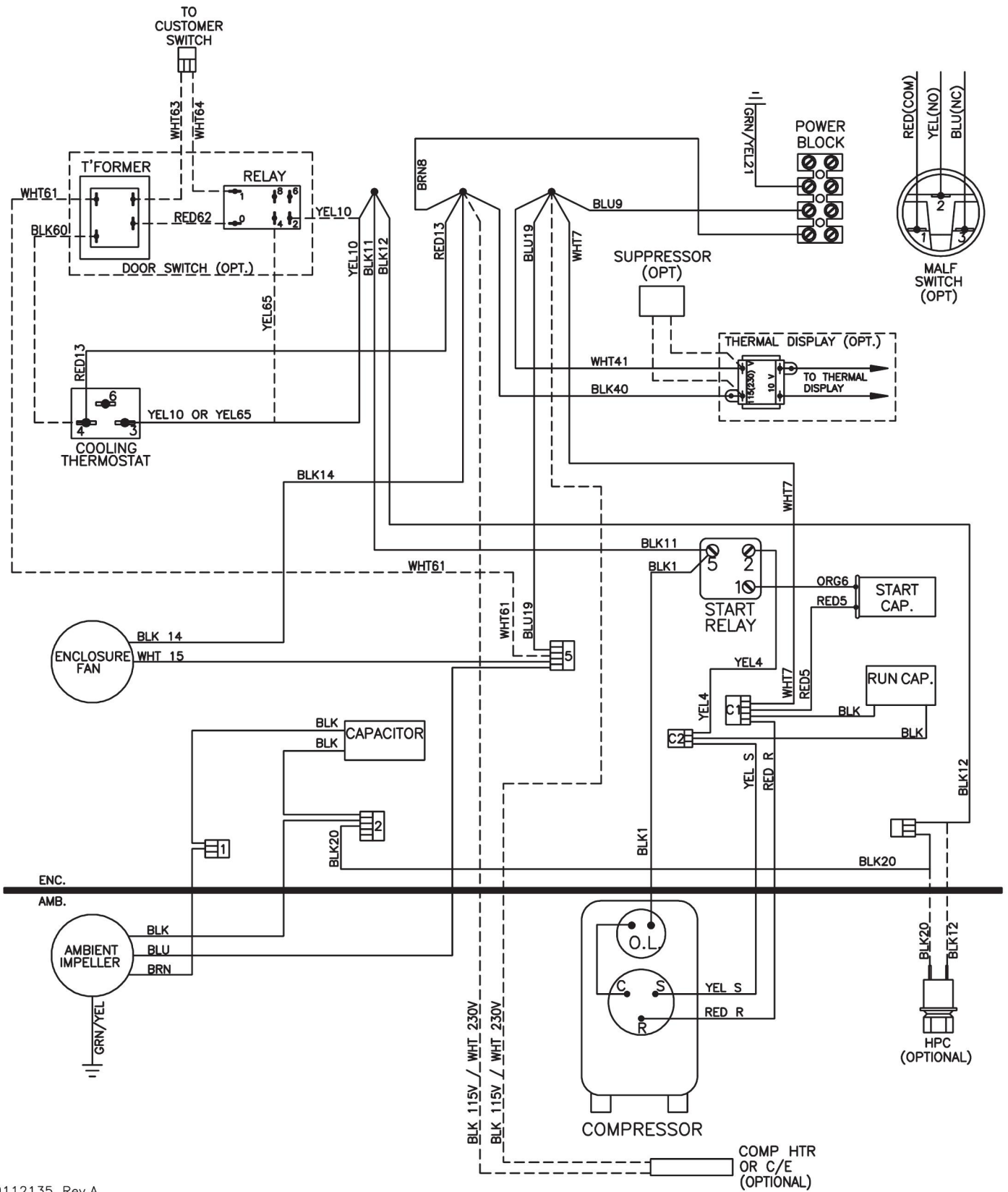

89112135 Rev.A

GENERIC 460V 1-PHASE WIRE DIAGRAM (ACTUAL UNIT OPTIONS MAY VARY)

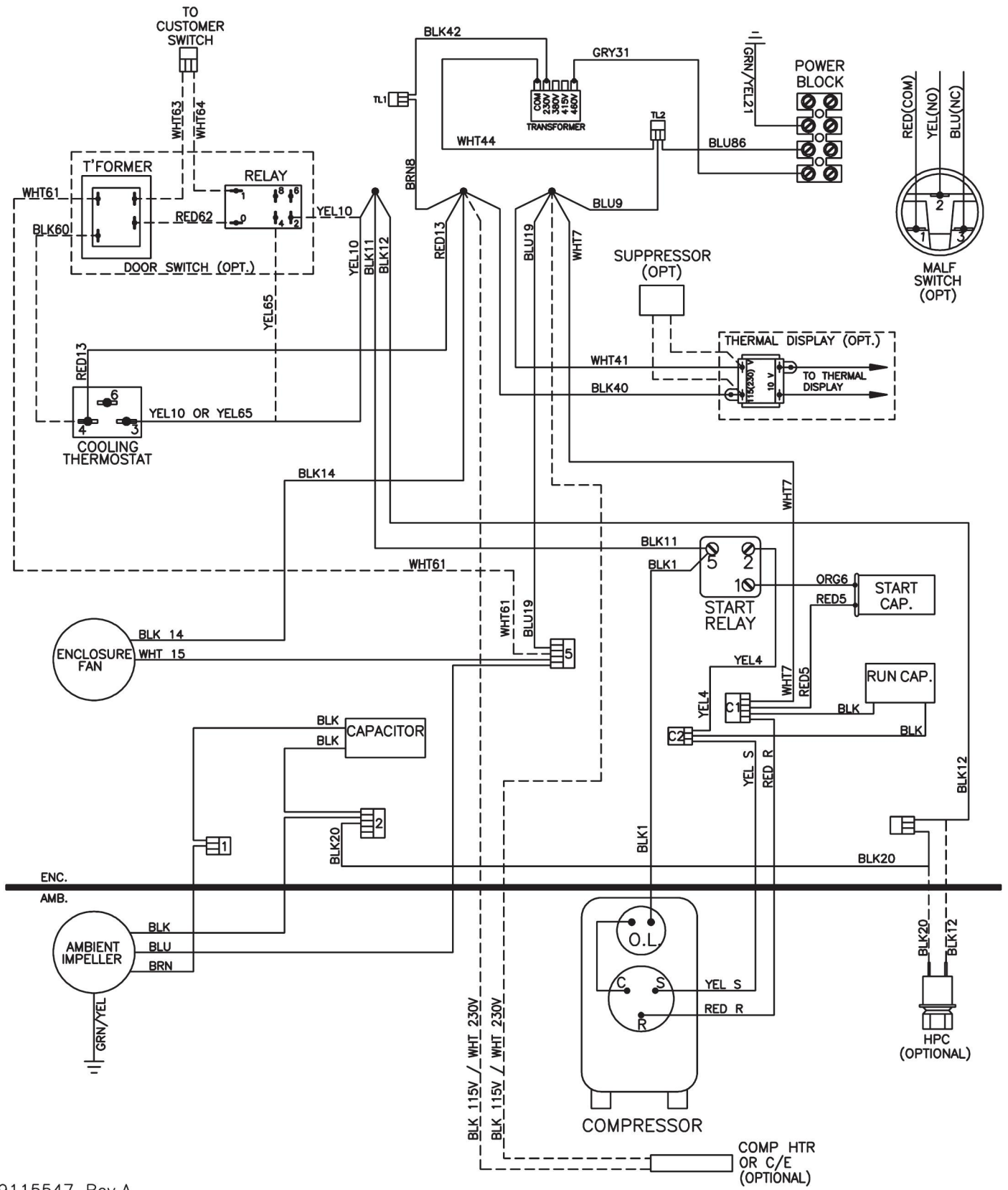

89115547 Rev.A

DIMENSIONAL DRAWING

WITH THERMOSTATS

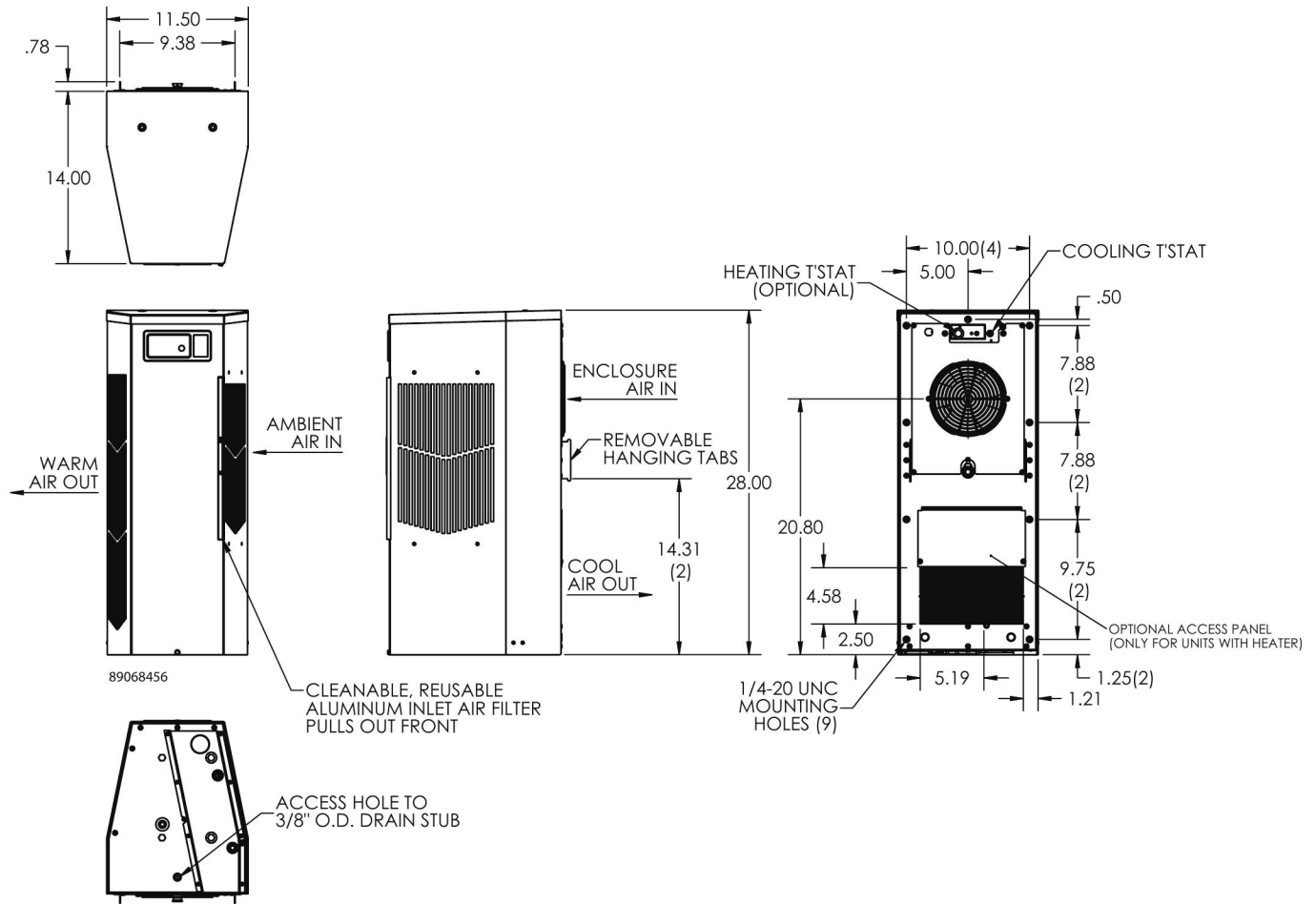

INSTALLATION INSTRUCTIONS

1. Inspect the air conditioner and verify correct functionality before mounting the air conditioner. See HANDLING AND TESTING THE AIR CONDITIONER on page 3.
2. Using the mounting gasket kit provided with the unit, install gaskets to the air conditioner, see Figure 1.
3. Mount air conditioner on enclosure taking care not to damage the mounting gasket. The mounting gasket is the seal between the air conditioner and the enclosure. Avoid dragging the air conditioner on the enclosure with the mounting gasket attached as this could cause rips or tears in the gasket and risk losing the water tight seal.
4. To avoid cross-threading mounting inserts, start bolts by hand before tightening with a wrench or ratchet driver.
5. Allow unit to remain upright for a minimum of five (5) minutes before starting. CAUTION! Air conditioner must be in upright position during operation.
6. Refer to the nameplate for electrical requirements. Wire the unit to a properly grounded power supply. Electrical circuit should be fused with slow blow or HACR circuit breaker.
7. Some air conditioners require a remote mounted thermostat. Wire the thermostat outputs to the appropriate terminals on the 24 VAC terminal strip by noting the locations on the correct wiring diagram.
8. Set thermostat for required cabinet temperature. Refer to Sequence of Operation on page 4 for thermostat adjustment and operation.

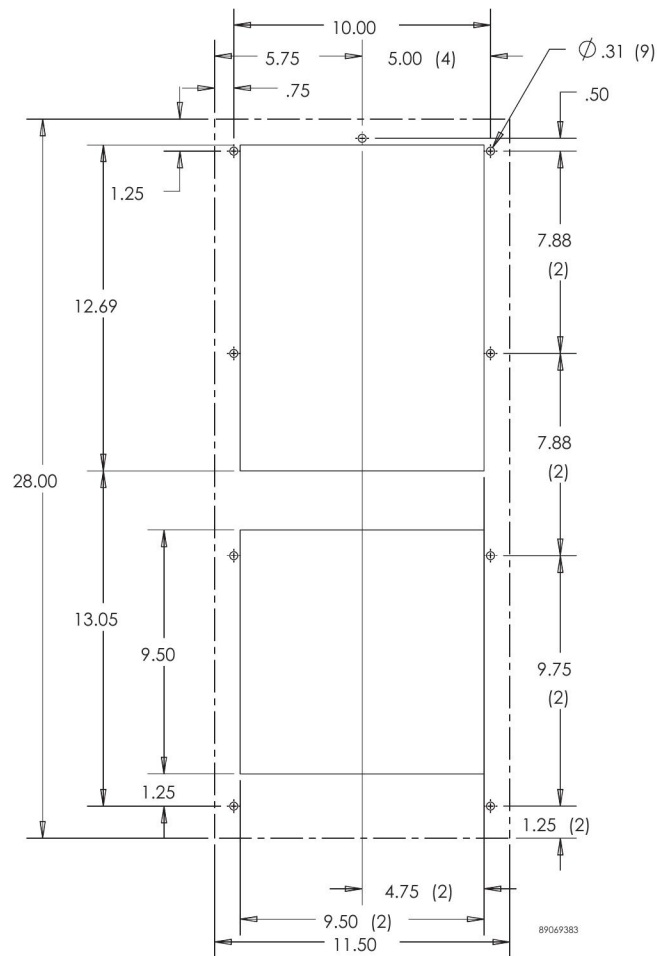

Surface Mount

Figure 1
Cut-out Drawing

REMOTE ACCESS CONTROL (OPTIONAL)

INTRODUCTION

The Remote Access Control is a parametric controller for the complete management of air conditioners. All settings are pre-programmed at the factory. Cooling/heating set-points, cooling/heating differential and high /low temperature alarm set-points can be adjusted by the user. Alarms are outputted through a relay contact and also can be accessed through an Ethernet connection utilizing SNMP, EtherNet/IP and Modbus TCP. A USB connection is also provided and can be used to interface with the controller utilizing Modbus RTU.

ENERGIZING THE CONTROLLER

The controller is wired and programmed at the factory to be energized when power is supplied to the air conditioner.

CONTROL STATUS INDICATION

The display has numerous symbols that indicate if the controller is heating, cooling, alarming, if the compressor is enabled, and if the ambient fan is enabled. The 3 alpha-numeric characters further describe alarms and show the cabinet temperature by default.

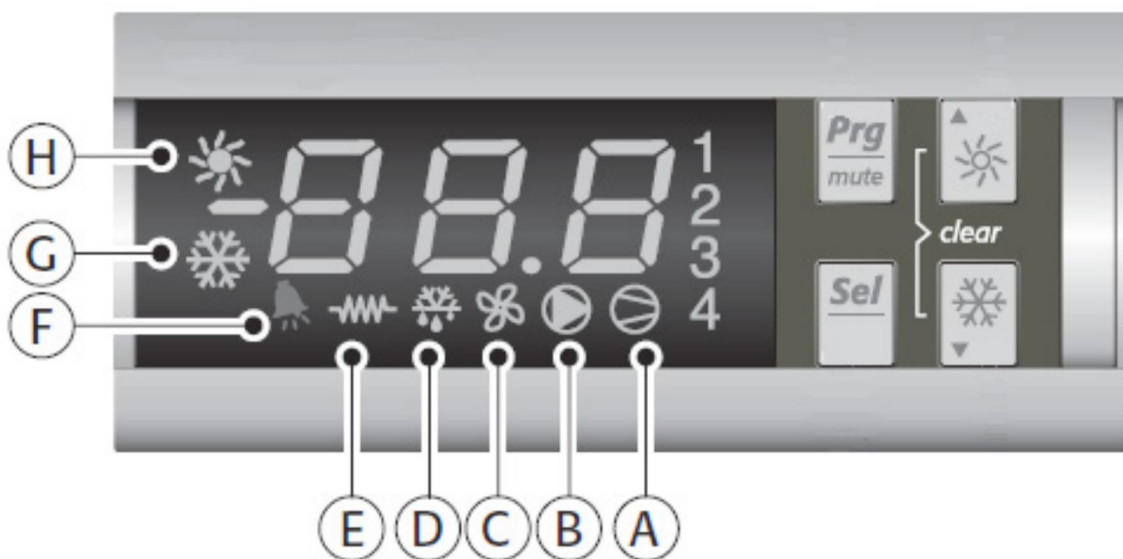

SYMBOL	COLOR	ICON ON	ICON FLASHING
1	AMBER	Compressor On	Start-up Request
2,3,4	AMBER	Not Used	Not Used
A	AMBER	Compressor On	Not Used
B	AMBER	Evaporator Fan On	Start-up Request
C	AMBER	Not Used	Not Used
D	AMBER	Not Used	Not Used
E	AMBER	Heater Active	Not Used
F	RED	Alarm Active	Not Used
G	AMBER	Controller Active	Not Used
H	AMBER	Not Used	Not Used

DISPLAYING AND CHANGING PROGRAM VARIABLES

Access: To view and/or change parameters, press and hold the Prg and Sel buttons for greater than 5 seconds. Press the up or down arrow buttons until "22" is displayed, then press Sel button. When "S-P" is displayed, press Sel.

Navigation: Press up or down arrows to display sub-menus then press Sel to select the desired sub-menu. In the sub-menu, use up or down arrows to display parameters for viewing or changing and press Sel. Use Prg button to back out of menu levels as desired.

Adjust: Use the up or down arrows to change the parameter value then push Sel to save that setting. If Sel is not pressed, the change to the value will not be saved. Navigate to and change other parameters as desired. When finished, push Prg to back out of the sub-menus to the main menu.

NOTE: The display will revert to normal temperature display mode if no buttons are pressed for 60 seconds.

OPERATING PARAMETERS

Parameter	Default Value	Range	Description
r01	80 F	72 F to 120 F	Cooling set-point
r02	7 F	-	Cooling differential
A04	50 F*	32 F to 60 F	Heating set-point*
A05	7 F*	-	Heating differential*

Cooling turns on at r01 + r02, and off at r01

Heating turns on at A04, and off at A04 + A05

*Functional only on units with heater option

ALARM PARAMETERS

Parameter	Default Value	Description
P16	125 F	High Temperature Alarm
P19	40 F	Low Temperature Alarm

DISPLAYING TEMPERATURE SENSOR #2

Sensor number 2, the air outlet or condenser coil sensor, can be viewed at any time by pressing the up or down arrow button on the front panel of the controller display. The display will revert to displaying temperature sensor number 1 (the AC inlet temperature) after 60 seconds. Both sensors can also be read through the Ethernet and USB connections.

COMPRESSOR RESTART TIME DELAY

A factory set 6 minute (360 second) restart delay exists to reduce residual back pressure before allowing the compressor to restart. The compressor will stay off for the entire restart duration after the compressor is disabled. A flashing "1" on the controller display will indicate the unit is in a compressor restart delay while calling for cooling.

ALARM OUTPUT CONTACT

The Remote Access Control has a normally open dry contact alarm output with a resistive load rating of 250 VAC at 3 amps. Two yellow 18 AWG wires located at the back of the air conditioner provide a connection to this output.

ALARM INPUT CONNECTION

The Remote Access Control can accept a dry contact/switch input via the two 18 AWG white wires located at the back of the air conditioner. This input is associated with the controller display alarm mnemonic TP (door open and/or smoke detected). [To use this feature, remove the splice connector connecting the two white wires and connect customer supplied enclosure door switch in its place.]

ALARM CONDITION DISPLAY

There are seven possible non-latching alarm conditions detectable by the controller and are indicated on the controller display. All alarms can also be accessed through the Ethernet and USB connections.

Alarm Mnemonic	Description	Cause	Result	Alarm Relay
TP	General Alarm	Door open and/or smoke detected	Unit turns off for duration of alarm	Relay Contacts Close
LA	High Pressure Warning	MALF high pressure switch opens	No effect on function	N/A
E1	Air Inlet Temperature Sensor Alarm	Sensor Failure	Unit turns off for duration of alarm	Relay Contacts Close
E2	Air Outlet Temperature Sensor Alarm	Sensor Failure	Unit turns off for duration of alarm	Relay Contacts Close
Ht	High Temperature Alarm Default = 125 F	Cabinet over temperature Alarm clears at default setting -2 F	No effect on function	Relay Contacts Close
Lt	Low Temperature Alarm Default = 40 F	Cabinet under temperature Alarm clears at default setting +27 F	No effect on function	N/A
A1	Frost Alarm	Evaporator coil frozen Alarm clears at 59 F	Compressor and Evaporator fan off for duration of alarm	Relay Contacts Close

AIR CONDITIONER UNIT COMMUNICATION FEATURES

Air conditioner units equipped with communication capabilities provide SNMP, EtherNet/IP and Modbus TCP protocols through Ethernet and Modbus RTU protocol via USB. Hoffman® Cooling has a PC Interface Tool available for download that can utilize either mode to communicate with the air conditioner unit.

USB COMMUNICATION

This communication mode allows direct connection of a PC to the air conditioner unit. The protocol supported is Modbus RTU. Use the PC Interface Tool to communicate with the air conditioner unit. A MINI-b USB connection is provided.

ETHERNET COMMUNICATION

This communication mode allows remote connection to the air conditioner unit using SNMP, EtherNet/IP and Modbus TCP protocols. Customers using their own software can download a MIB file for SNMP, EDS file or EtherNet_IP Object file for EtherNet/IP and Coil_Register file for Modbus TCP.

Note: ACU has a default IP Address of 192.168.1.2

Both Ethernet and USB communication modes allow the ability to:

- Read ACU inlet and outlet air temperatures
- Read and change Cooling Set-point and Cooling Differential
- Read and change Heating Set-point, Heating Differential
- Read and change High and Low Temperature Alarm Settings
- Read and change Gateway IP Address, Device IP Address, Subnet Mask, Trap IP Address and Community
- Read and change Unit Identification
- Read and change the state of IP addressing (static or dynamic)
- Read current Alarm Status

SOFTWARE AND CONFIGURATION FILE DOWNLOADS

The PC Interface Tool, MIB file, EDS file, EtherNet_IP Object file and Coil_Register file can be downloaded from www.hoffmanonline.com.

USING THE PC INTERFACE TOOL

The PC Interface Tool gives the user the ability to communicate with the air conditioner unit to read/write parameters using either Ethernet or USB connections.

USB COMMUNICATION MODE

NOTE: Before connecting unit to the PC, make note of the comm ports present. After the unit is connected to the PC, a new comm port will be added to the list. Use this new comm port.

- From **Tools** menu select **Use Ethernet**
- When **Use Ethernet** is unchecked, then **Comm Port** menu is enabled, **Device IP** and **Community** boxes are not shown, and USB communication can be used
- To set the comm port, choose **Comm Port** from the **Tools** menu and then select the comm port from the combo box

VIEWING AIR CONDITIONER UNIT VALUES

To view Air Conditioner Unit values

- Select the **ACU Values** tab
- Select the **Enable Comm** button (the PC Interface will now be communicating with unit)
- To stop communication select the **Disable Comm** button

CHANGING AIR CONDITIONER UNIT VALUES

To change **ACU Values**

- Select the **Settings** tab
- Select the value to change
- Make the change to the value
- Select the **Change Setting** button
- Change can be verified in **ACU Values** tab

VIEWING AND CHANGING ETHERNET INFORMATION

To view and change Ethernet Information

- Select **Ethernet Info** tab

To view Ethernet Information

- Click **Read Ethernet Info** button

To change to dynamically assigning IP Address Mode

- Check **Use DHCP Server** checkbox
- Enter Trap IP Address and Community
- Click **Load Ethernet Info** button

To change to statically assigning IP Address Mode

- Uncheck **Use DHCP Server** checkbox
- Enter Device IP Address, Subnet Mask, Gateway IP Address, Trap IP Address and Community
- Click **Load Ethernet Info** button

ETHERNET COMMUNICATION MODE

- From **Tools** menu select **Use Ethernet**
- When **Use Ethernet** is checked, **Comm Port** selection is disabled, **Device IP** and **Community** boxes are shown and Ethernet communication can be used.
- Enter unit's IP Address and Community string in **Device IP** and **Community** boxes at the bottom of the PC Interface Tool.

Each unit has two community strings. One is a Read/Write community string (defaulted to 'private') that can be changed by the customer (must be 4 to 8 characters long). The other is a Read-Only community string ('public') and cannot be changed.

VIEWING AIR CONDITIONER UNIT VALUES

To view Air Conditioner Unit values

- Select the **ACU Values** tab
- Select the **Enable Comm** button (the PC Interface will now be communicating with unit)
- To stop communication select the **Disable Comm** button

CHANGING AIR CONDITIONER UNIT VALUES

To change **ACU Values**

- Select the **Settings** tab
- Select the value to change
- Make the change to the value
- Select the **Change Setting** button
- Change can be verified in **ACU Values** tab

VIEWING AND CHANGING ETHERNET INFORMATION

To view and change Ethernet Information

- Select **Ethernet Info** tab

To view Ethernet Information

- Click **Read Ethernet Info** button

To change to dynamically assigning IP Address Mode

- Check **Use DHCP Server** checkbox
- Enter Trap IP Address and Community
- Click **Load Ethernet Info** button

To change to statically assigning IP Address Mode

- Uncheck **Use DHCP Server** checkbox
- Enter Device IP Address, Subnet Mask, Gateway IP Address, Trap IP Address and Community
- Click **Load Ethernet Info** button

ALARM LOG ACCESSIBLE WITH SNMP

- Using custom software with the provided MIB file gives the ability to view a log of the last 25 alarms

REMOTE ACCESS CONTROL PIN-OUT

	FUNCTION	NAME	PIN #	WIRE #
U1 OUTPUTS	COOL	No1	1	ORG78
		C1/2	2	BLK
	HEAT	No2	7	BRN76
		C1/2	3	BLK
	ENCL MI	No3	8	BLK77
		C3/4	4	BLK
	NA	No4 (na)	9	BLK
		C3/4	10	BLK
	ALARM RELAY OUTPUT	No5	12	YEL39
		C5	6	YEL38
	NA	x	5	NA
NA	x	11	NA	
U2 INPUTS	ALARM INPUT CONNECTION	ID1	8	WHT63
	MALFUNCTION NC SWITCH	ID2	1	BLU88
	NA	ID3 (na)	9	BLU
	NA	ID4 (na)	2	BLU
	NA	ID5 (na)	10	BLU
	DIGITAL INPUT GROUND	ID GND	3	BLU
	NA	Y (na)	4	NA
	NA	GND (na)	5	NA
	T1, EVAP IN THERMISTOR	B1	13	RED
	T2, EVAP OUT THERMISTOR	B2	12	RED
	T1, T2 GND	GND	6	WHT
	NA	B3	11	NA
	CONTROLLER POWER	G	7	BLK40
	CONTROLLER POWER	G0	14	WHT41
U3 DATA	POWER		1	RED
	GROUND		2	BLACK
	DIRECTION		3	GREEN
	DATA		4	WHITE

SCHEMATICS AND WIRING DIAGRAMS FOR REMOTE ACCESS CONTROL

GENERIC 115V 1-PHASE SCHEMATIC (ACTUAL UNIT OPTIONS MAY VARY)

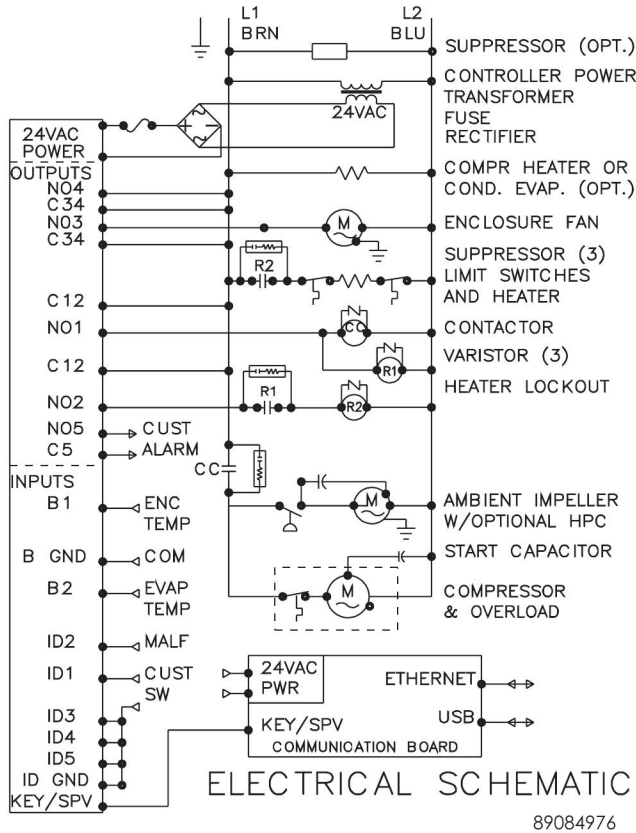

GENERIC 230V 1-PHASE SCHEMATIC (ACTUAL UNIT OPTIONS MAY VARY)

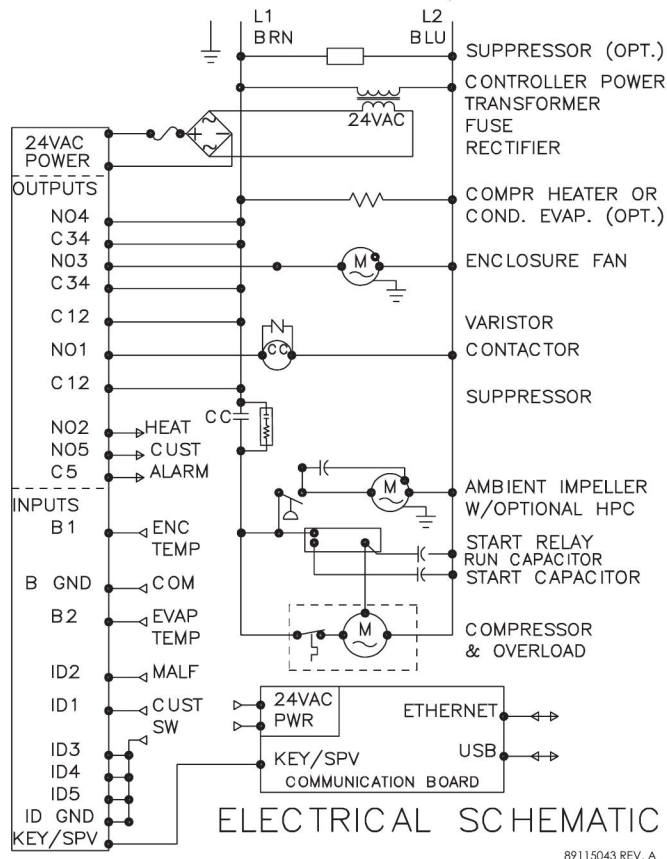

GENERIC 460V 1-PHASE SCHEMATIC (ACTUAL UNIT OPTIONS MAY VARY)

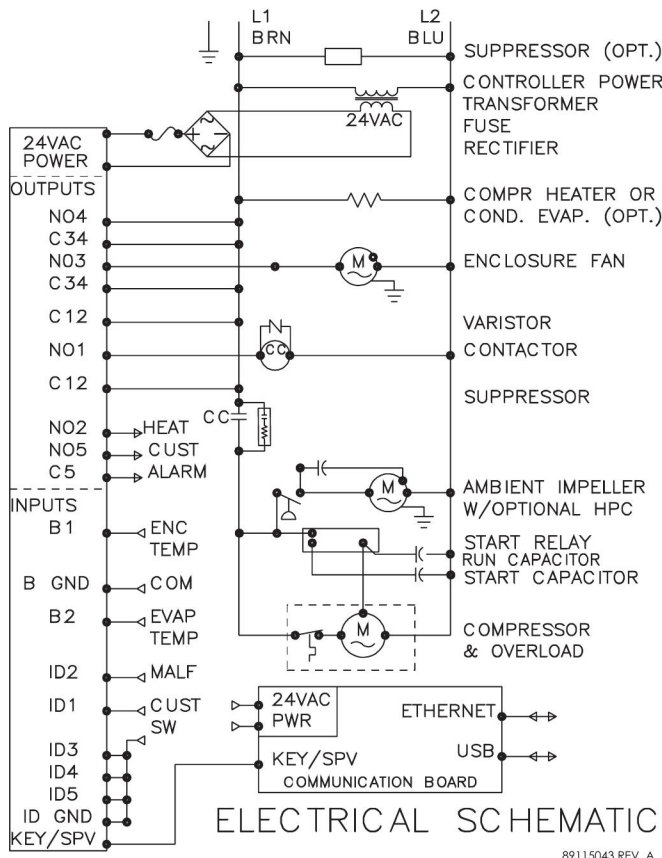

GENERIC 115V 1-PHASE WIRE DIAGRAM FOR REMOTE ACCESS CONTROL (ACTUAL UNIT OPTIONS MAY VARY)

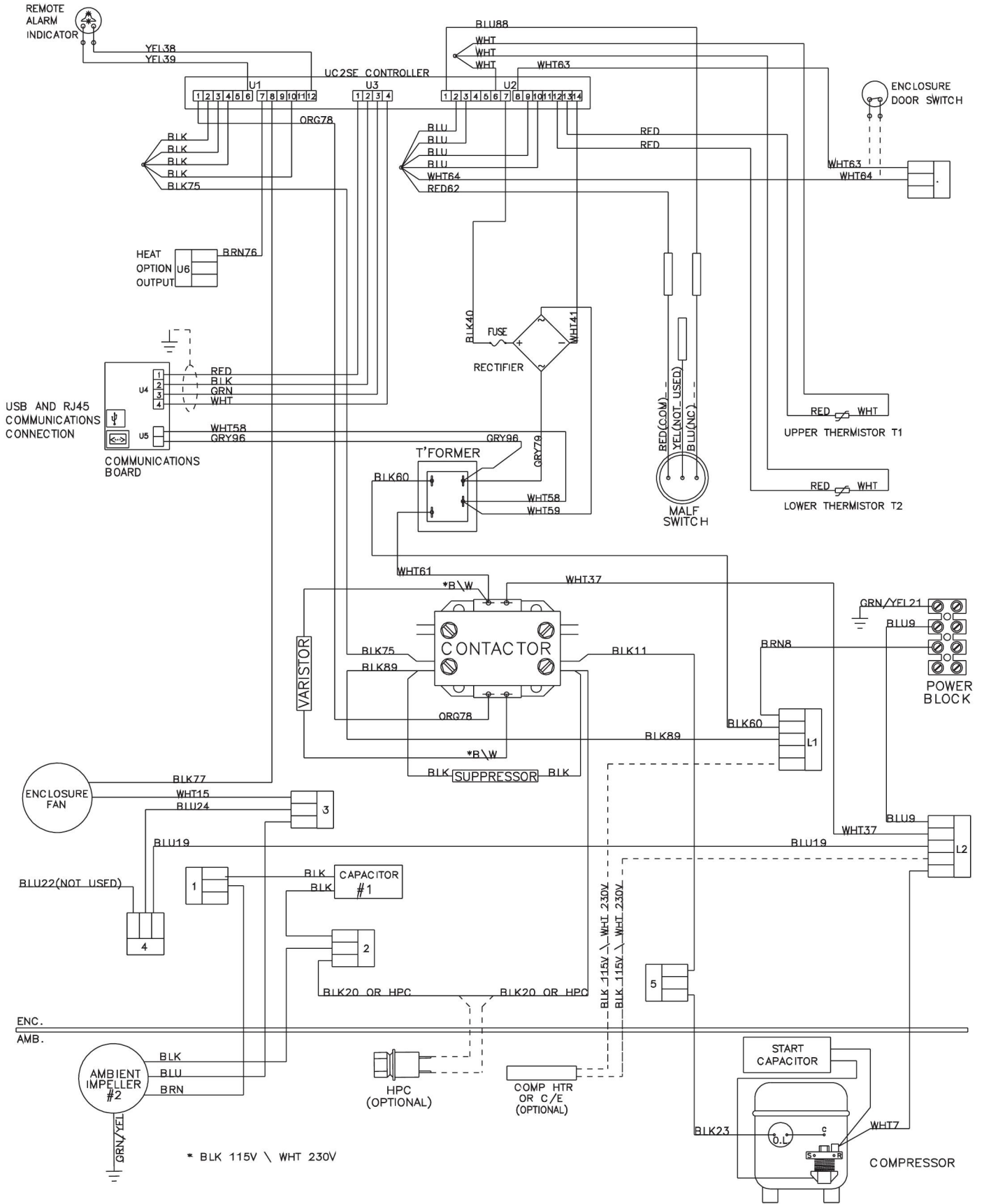

89082437

GENERIC 230V 1-PHASE WIRE DIAGRAM FOR REMOTE ACCESS CONTROL (ACTUAL UNIT OPTIONS MAY VARY)

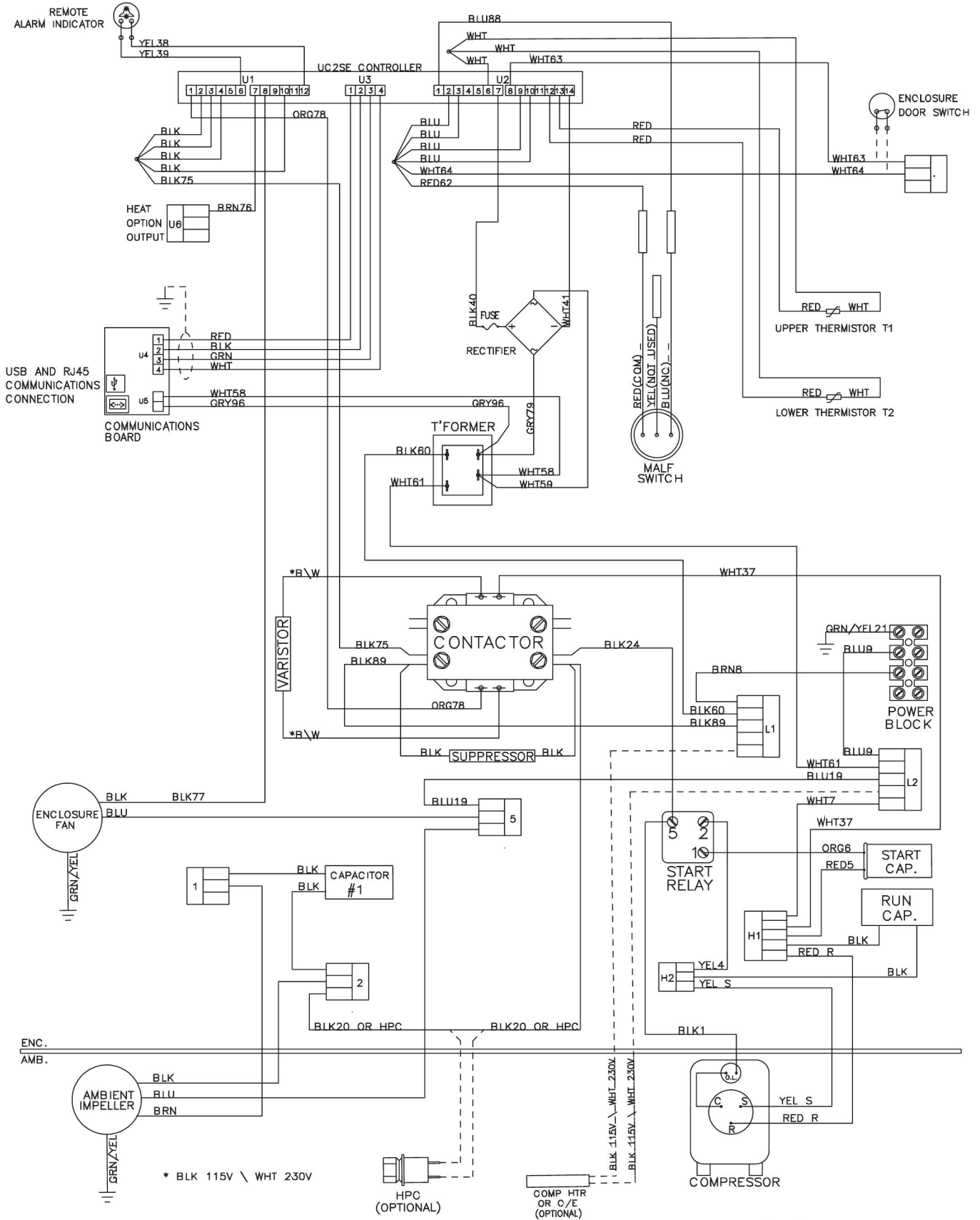

89115041 REV.A

GENERIC 460V 1-PHASE WIRE DIAGRAM FOR REMOTE ACCESS CONTROL (ACTUAL UNIT OPTIONS MAY VARY)

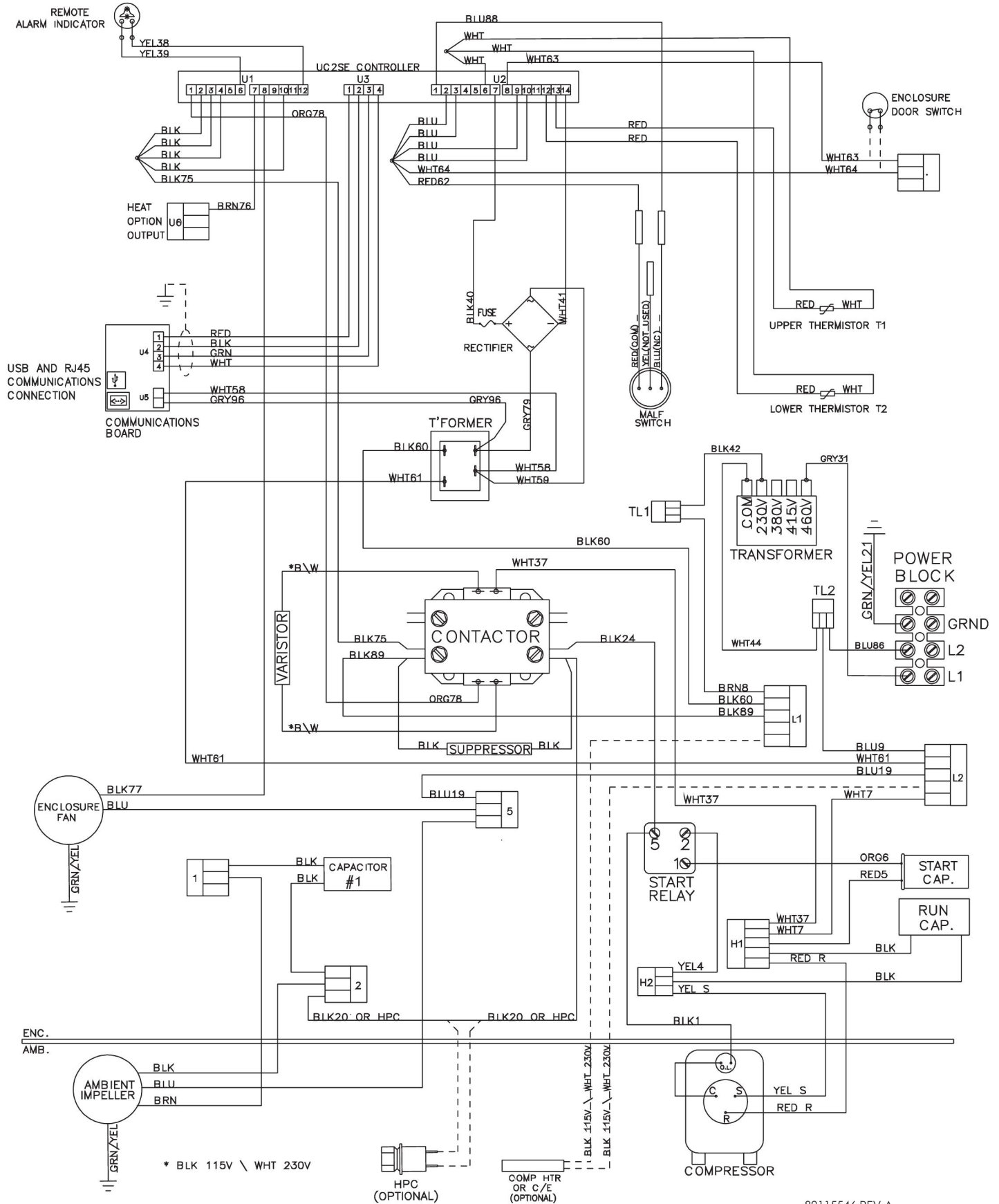

89115546 REV.A

DIMENSIONAL DRAWING

WITH REMOTE ACCESS CONTROL

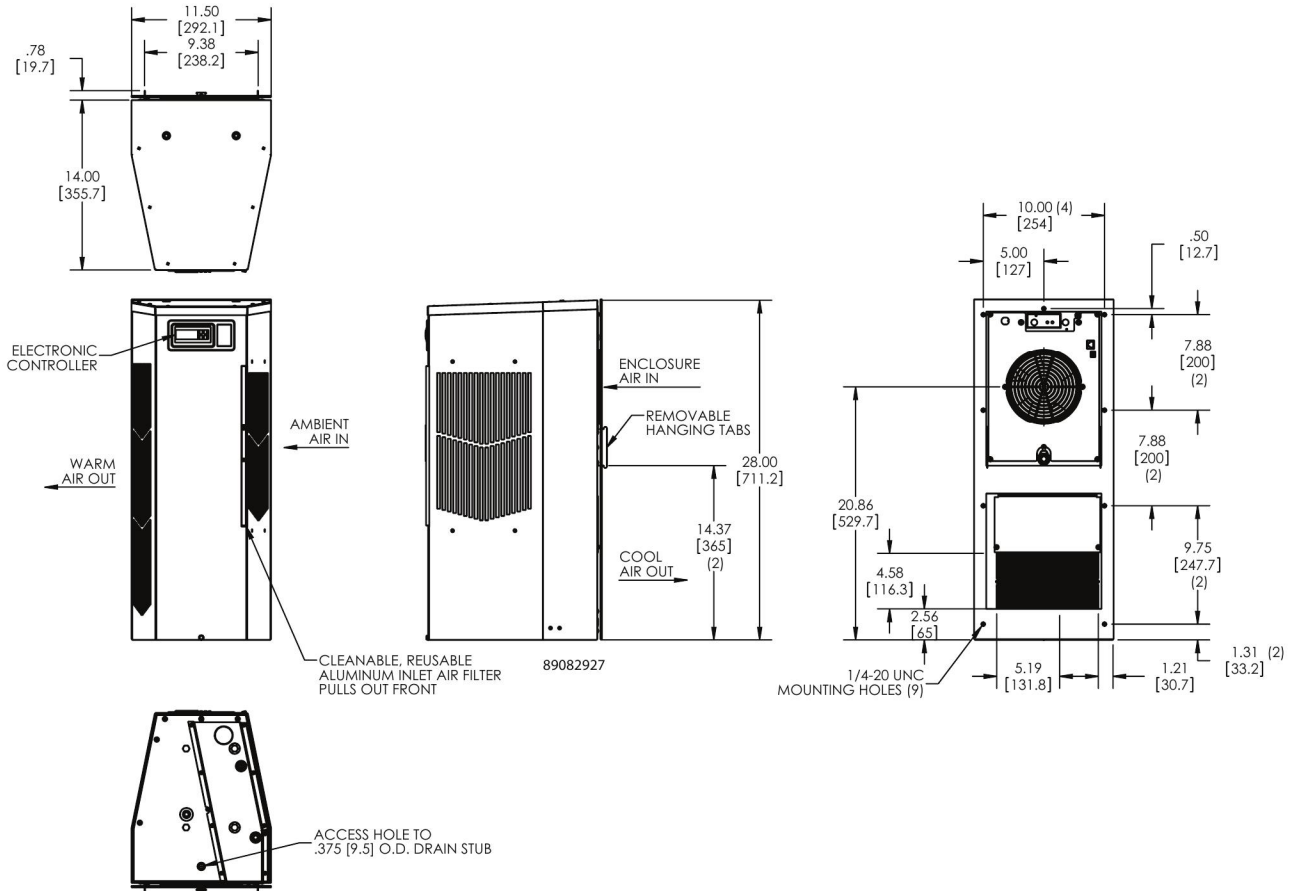

INSTALLATION INSTRUCTIONS WITH REMOTE ACCESS CONTROL

1. Inspect the air conditioner and verify correct functionality before mounting the air conditioner. See HANDLING AND TESTING THE AIR CONDITIONER on page 3.
2. Using the mounting gasket kit provided with the unit, install gaskets to the air conditioner, see Figure 2.
3. Mount air conditioner on enclosure taking care not to damage the mounting gasket. The mounting gasket is the seal between the air conditioner and the enclosure. Avoid dragging the air conditioner on the enclosure with the mounting gasket attached as this could cause rips or tears in the gasket and risk losing the water tight seal.
4. Allow unit to remain upright for a minimum of five (5) minutes before starting. CAUTION! Air conditioner must be in upright position during operation.
5. Refer to the nameplate for electrical requirements. Wire the unit to a properly grounded power supply. Electrical circuit should be fused with slow blow or HACR circuit breaker.
6. Set controller setpoints for required cabinet temperature. Refer to Displaying and Changing Program Variables on page 13 for setpoint adjustment and operation.

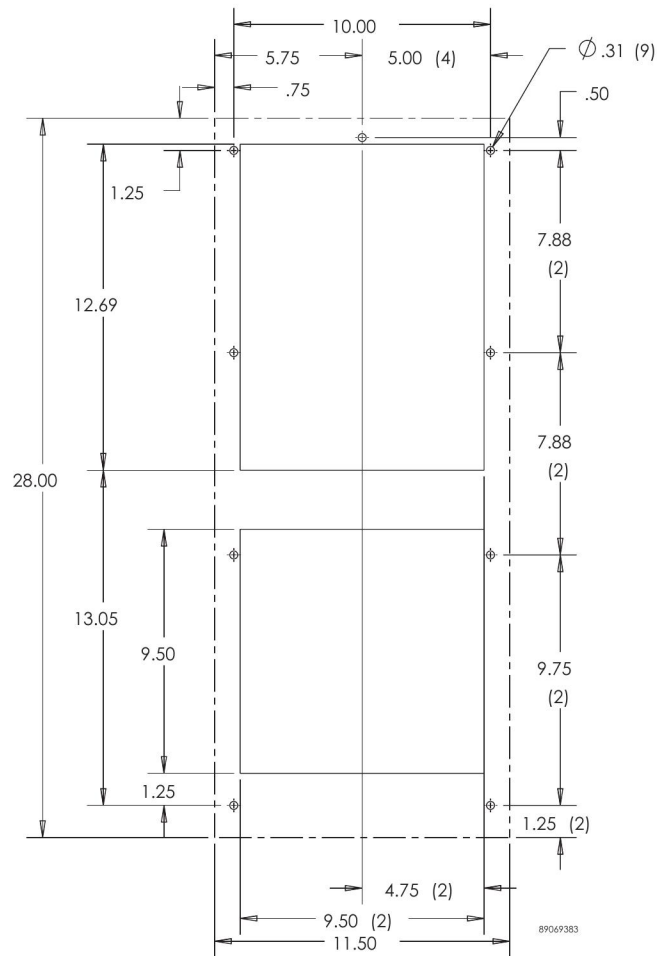

Surface Mount

Figure 2
Cut-out Drawing

MAINTENANCE

COMPRESSOR

The compressor requires no maintenance. It is hermetically sealed, properly lubricated at the factory and should provide years of satisfactory operating service.

Under no circumstances should the access fitting covers be loosened, removed or tampered with.

Breaking of seals on compressor access fittings during warranty period will void warranty on hermetic system.

Recharging ports are provided for the ease and convenience of reputable refrigeration repair service personnel for recharging the air conditioner.

INLET AIR FILTER

This air conditioner was designed with a dust resistant condenser coil. This allows it to be run filterless in most applications. The air conditioner is shipped with a filter in place for your convenience. For filterless operation, simply remove the filter. Should you decide the filter is necessary in your application, regular maintenance to clean this filter will assure normal operation of the air conditioner. The easily removable inlet air filter is located behind the front cover. If necessary filter maintenance is delayed or ignored, the maximum ambient temperatures under which the unit is designed to operate will be decreased.

If the compressor's operating temperature increases above designed conditions due to a dirty or clogged filter (or plugged condenser coil), the air conditioner's compressor will stop operating due to actuation of the thermal overload cut-out switch located on the compressor housing. As soon as the compressor temperature has dropped to within the switch's cut-in setting, the compressor will restart automatically. However the above condition will continue to take place until the filter or coil has been cleaned. It is recommended that power to the air conditioner be interrupted intentionally when abnormally high compressor operating temperature causes automatic shut-down of the unit. The above described shut-down is symptomatic of a clogged or dirty filter, thus causing a reduction in cooling air flow across the surface of the compressor and condenser coil.

HOW TO REMOVE, CLEAN OR INSTALL A NEW INLET AIR FILTER

RP aluminum washable air filters are designed to provide excellent filtering efficiency with a high dust holding capacity and a minimum amount of resistance to air flow. Because they are constructed entirely of aluminum they are lightweight and easy to service. To achieve maximum performance from your air handling equipment, air filters should be cleaned on a regular basis.

The inlet air filter is located behind the front access cover. To access the filter, loosen the access-cover screw. Swing top edge of access cover forward. Slide air filter up and out of retaining tabs. The filter may now be cleaned or new filter installed.

Cleaning Instructions:

1. Flush the filter with warm water from the exhaust side to the intake side. **DO NOT USE CAUSTICS.**
2. After flushing, allow filter to drain. Placing it with a corner down will assure complete drainage.

CONDENSER AND EVAPORATOR AIR MOVERS

Impeller motors require no maintenance. All bearings, shafts, etc. are lubricated during manufacturing for the life of the motor.

If one of the condenser impeller motors (ambient impellers) should fail, it is not necessary to remove the air conditioner from the cabinet or enclosure to replace the blower. The condenser blower is mounted on its own bulkhead and is easily accessible by removing the front cover.

 CAUTION	
Operation of the air conditioner in areas containing airborne caustics or chemicals can rapidly deteriorate filters, condenser coils, blowers and motors, etc. Contact nVent Equipment Protection for special recommendations.	

REFRIGERANT LOSS

Each air conditioner is thoroughly tested prior to leaving the factory to insure against refrigeration leaks. Shipping damage or microscopic leaks not found with sensitive electronic refrigerant leak detection equipment during manufacture may require repair or recharging of the system. This work should only be performed by qualified professionals, generally available through a local, reputable air conditioning repair or service company.

Should the refrigerant charge be lost, access ports on the suction and discharge sides of the compressor are provided for recharging and/or checking suction and discharge pressures.

Refer to the data on the nameplate which specifies the type of refrigerant and the charge size in ounces.

Before recharging, make sure there are no leaks and that the system has been properly evacuated into a deep vacuum.

REFRIGERANT PROPERTIES CHART (R134A)

°F	°C	Pressure	°F	°C	Pressure
-40	-40	-14.7	60	15.6	58
-35	-37.2	-12.3	65	18.3	64
-30	-34.4	-9.7	70	21.1	71.5
-25	-31.7	-6.8	75	23.9	78
-20	-28.9	-4	80	26.7	86.7
-15	-26.1	0	85	29.4	95
-10	-23.3	2	90	32.2	105
-5	-20.6	4	95	35	113.3
0	-17.8	7.5	100	37.8	125
5	-15	9	105	40.6	135
10	-12.2	12	110	43.3	146.7
15	-9.4	15	115	46.1	157.5
20	-6.7	18.5	120	48.9	170
25	-3.9	22	125	51.7	185
30	-1.1	26			
35	1.7	30			
40	4.4	35			
45	7.2	40			
50	10	45.5			
55	12.8	51.5			

UNIT CHARACTERISTICS

	Model		
	N280416GXXX	N280426GXXX	N280446GXXX
Dimensional Data			
Height	28" / 711.2 mm		
Width	11.5" / 292.1 mm		
Depth	14" / 355.6 mm		
Unit Weight	84 lbs / 38 kg	84 lbs / 38 kg	98 lbs / 44 kg
Unit Protection Rating	Type 12/4/4X/3R		
Cooling Data			
Refrigerant	R134a		
Refrigerant Charge	10 oz.	11 oz.	11 oz.
Cooling Capacity at 95 F Enclosure 95 F Ambient (BTU/Hr.)	3754/4011	3706/4291	4291
Cooling Capacity at Max Conditions (BTU/Hr.)	3940/4104	4269/4703	4703
Maximum Ambient Temp	125 F / 52 C		
Minimum Ambient Temp	-40 F / -40 C		
Enclosure Airflow	143 CFM		
External Airflow	288 CFM		
Condensate Management	Hose discharge / Optional powered C/E		
Heating Data			
Capacity	1300 W		N/A
Electrical Data			
Rated Voltage (50/60 Hz)	115 V	230 V	460 V
Rated Frequency	50/60 Hz	50/60 Hz	60 Hz
Voltage Range	+/- 10% of rated		
Cooling Amps at Max Conditions	10.6/10.0	4.9/5.0	2.5
Heating Amps	12.2	6.2	N/A
Compressor RLA / LRA	7.75/42	3.12/24.5	3.12/24.5
Evaporator Fan RLA	.38/.36	.19	.19
Condenser Fan RLA	.78/.93	.53	.53

FUNCTIONAL DATA

Unit	Evaporator. Air In(°F)	Amps(A)	Condenser Delta(°F)	Evaporator Delta(°F)
N280416GXXX	65-80	7-7.4	15-22	13-28
	80-100	7.4-8.6	21-25	14-24
N280426GXXX	65-80	3.1-3.7	17-25	15-27
	80-100	3.4-4.1	19-29	14-31
N280446GXXX	65-80	1.5-1.9	17-25	15-27
	80-100	1.7-2.1	19-29	14-31

SERVICE DATA

COMPONENTS LIST

Part Description	Part Number		
	115 V	230 V	460 V 60 Hz
Capacitor, Compressor, Start	89112001SP	10103208SP	10103208SP
Capacitor, Condenser Impeller	52603213SP	52603214SP	52603214SP
Coil, Condenser	89068416SP	89068416SP	89068416SP
Coil, Evaporator	89068414SP	89068414SP	89068414SP
Compressor	89111751SP	89111752SP	89111752SP
Filter, Air, Reusable	89068420SP	89068420SP	89068420SP
Filter/Dryer	52602800SP	52602800SP	52602800SP
Head Pressure Control Switch (option)	52610426SP	52610426SP	52610426SP
Impeller, Condenser	101091123SP	101091124SP	101091124SP
Fan, Evaporator	12101201SP	12101202SP	12101202SP
Relay, Compressor Start	89115078SP	89112003SP	89112003SP
Run Capacitor	N/A	52603220SP	52603220SP
Capillary Tube	99054039SP	99064045SP	99064045SP
Thermostat, SPDT, 55-100F	10106116SP	10106116SP	10106116SP
Transformer, Input Power	N/A	N/A	101006111SP
Overload	89114723SP	89114724SP	89114724SP
Controller, Basic	89075653SP		
Thermistor	89075654SP		
Bridge Rectifier	89087424SP		
Controller Wires with pins (24)	89083091SP		
Communication Board	89082033SP		
Communication Cable	89080313SP		
315 mA Fuse	89085115SP		

N280416GXXX PRESSURE TABLES

N280416GXXX 50hz		L=SUCTION (± 5PSIG); H=HEAD (-10/+20PSIG)															
Ambient Temperature (°F)		ENCLOSURE TEMPERATURE (°F)															
		70		80		90		95		100		113		120		125	
		L	H	L	H	L	H	L	H	L	H	L	H	L	H	L	H
70		23	118	25	121	27	124	28	125	28	127	31	131	32	133	33	134
80		25	145	27	149	29	153	30	154	31	156	34	161	35	163	36	165
90		28	173	30	177	32	181	33	183	34	185	37	190	39	193	40	195
95		29	186	31	191	34	195	35	197	36	199	39	205	41	208	42	210
100		30	200	32	205	35	209	36	212	37	214	40	220	42	223	43	226
113		33	235	36	241	39	246	40	249	41	252	45	259	47	263	48	265
120		35	254	38	260	40	266	42	269	43	272	47	280	48	284	50	287
125		36	268	39	274	41	280	43	283	44	287	48	295	50	299	51	302

N280416GXXX 60hz		L=SUCTION (± 5PSIG); H=HEAD (-10/+20PSIG)															
Ambient Temperature (°F)		ENCLOSURE TEMPERATURE (°F)															
		70		80		90		95		100		113		120		125	
		L	H	L	H	L	H	L	H	L	H	L	H	L	H	L	H
70		22	122	23	124	24	127	24	128	25	129	26	132	27	134	27	135
80		24	149	25	153	26	156	27	157	27	159	29	163	29	165	30	166
90		26	177	27	181	29	184	30	186	30	188	32	193	33	195	34	197
95		27	191	29	194	30	198	31	200	32	202	34	207	35	210	36	212
100		28	204	30	209	31	213	32	215	33	217	35	223	36	226	37	228
113		31	240	33	245	35	250	36	253	37	255	39	262	41	266	42	268
120		32	259	34	265	36	271	37	273	39	276	41	284	43	287	44	290
125		33	273	35	279	38	285	39	288	40	290	43	298	45	302	46	305

N280426GXXX PRESSURE TABLES

N280426GXXX 50hz			L=SUCTION (± 5PSIG); H=HEAD (-10/+20PSIG)														
Ambient Temperature (°F)	ENCLOSURE TEMPERATURE (°F)																
	°F	70		80		90		95		100		113		120		125	
		L	H	L	H	L	H	L	H	L	H	L	H	L	H	L	H
70	25	119	29	125	32	131	34	134	36	136	41	144	43	148	45	151	
80	28	145	32	152	35	158	37	162	39	165	44	173	47	178	48	181	
90	31	171	35	179	38	186	40	190	42	193	47	203	50	208	52	211	
95	32	184	36	192	40	200	42	204	44	207	49	217	52	223	54	226	
100	34	198	38	205	42	213	44	217	46	221	51	231	54	237	55	241	
113	37	232	41	240	46	249	48	253	50	258	55	269	58	275	60	280	
120	39	250	43	259	47	268	50	273	52	278	57	290	60	296	62	301	
125	41	263	45	273	50	282	52	287	54	292	59	304	62	311	64	316	

N280426GXXX 60hz			L=SUCTION (± 5PSIG); H=HEAD (-10/+20PSIG)														
Ambient Temperature (°F)	ENCLOSURE TEMPERATURE (°F)																
	°F	70		80		90		95		100		113		120		125	
		L	H	L	H	L	H	L	H	L	H	L	H	L	H	L	H
70	23	124	26	130	29	135	31	138	32	141	36	148	38	152	40	155	
80	26	151	29	157	32	163	34	167	36	170	40	178	42	183	44	186	
90	28	177	32	185	35	192	37	196	39	199	43	209	46	214	47	217	
95	30	191	33	198	37	206	38	210	40	214	45	224	47	229	49	233	
100	31	204	35	212	38	220	40	224	42	228	47	239	49	244	51	248	
113	35	239	39	248	42	257	44	262	46	266	51	278	54	284	56	289	
120	37	258	40	267	44	277	46	281	48	286	53	298	56	305	58	310	
125	38	271	42	281	46	291	48	296	50	301	55	314	58	321	60	326	

N280446GXXX PRESSURE TABLES

N280446GXXX 60hz			L=SUCTION (± 5PSIG); H=HEAD (-10/+20PSIG)														
Ambient Temperature (°F)	ENCLOSURE TEMPERATURE (°F)																
	°F	70		80		90		95		100		113		120		125	
		L	H	L	H	L	H	L	H	L	H	L	H	L	H	L	H
70	23	124	26	130	29	135	31	138	32	141	36	148	38	152	40	155	
80	26	151	29	157	32	163	34	167	36	170	40	178	42	183	44	186	
90	28	177	32	185	35	192	37	196	39	199	43	209	46	214	47	217	
95	30	191	33	198	37	206	38	210	40	214	45	224	47	229	49	233	
100	31	204	35	212	38	220	40	224	42	228	47	239	49	244	51	248	
113	35	239	39	248	42	257	44	262	46	266	51	278	54	284	56	289	
120	37	258	40	267	44	277	46	281	48	286	53	298	56	305	58	310	
125	38	271	42	281	46	291	48	296	50	301	55	314	58	321	60	326	

F-GAS INFORMATION

	N280416GXXX	N280426GXXX N280446GXXX N280425GXXX
Refrigerant Kühlmittel Chłodziwo	R134a	R134a
GWP	1430	1430
Factory Charge Füllmenge durch Hersteller Opłata Fabryczna	283 Grams 283 Gramm 283 Gramów	312 Grams 312 Gramm 312 Gramów
CO ₂ Equivalent CO ₂ Equivalent CO ₂ Ekwilalent	0.40 Tons 0,40 Tonnen 0,40Tony	0.45 Tons 0,45 Tonnen 0,45 Tony

TROUBLE SHOOTING

BASIC AIR CONDITIONING TROUBLE SHOOTING CHECK LIST - THERMOSTAT VERSION

1. Check manufacturer's nameplate located on the unit for correct power supply.
2. Turn on power to the unit. The evaporator (Enclosure or "COLD" air) impeller should come on. Is there airflow?

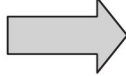
YES, proceed to step 3.
NO, possible problem: » Open motor winding » Stuck impeller motor » Obstructed wheel

Repair or Replace defective part

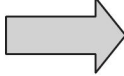
3. Check thermostat setting and adjust thermostat to the lowest setting. This should turn the condenser impellers and the compressor on. Did condenser impellers and compressor come on when the thermostat was turned on?

YES, proceed to step 4.
NO, possible problem: » Tripped customer door switch » Defective thermostat

Replace part

4. Are all impellers and the compressor running? If not the unit will not cool properly.
5. Check condenser (Ambient or "HOT" air) impellers for airflow. Is there airflow?

YES, proceed to step 6.
NO, possible problem: » Defective thermostat » Open motor winding » Stuck impeller motor » Obstructed wheel

Repair or Replace defective part

6. Carefully check the compressor for operation - motor should cause slight vibration, and the outer case of the compressor should be warm. Is the compressor showing signs of this?

YES, wait 5 minutes, then proceed to step 7.
NO, possible problem: » Defective thermostat » Defective overload » Defective relay

Repair or Replace defective part

7. Make sure the coils are clean. Then check evaporator "air in" and "air out" temperatures. If the temperatures are the same:

» Possible loss of refrigerant » Possible bad valves in the compressor

Repair or Replace defective part

8. To check for a bad thermostat, turn power to the unit off. Remove the upper access panel and place both thermostat wires onto one terminal (replace upper access panel for safety). This will activate the switch in the thermostat. Turn the power on and if all impellers and the compressor come on, the thermostat needs to be replaced.

SYMPTOMS AND POSSIBLE CAUSES - THERMOSTAT VERSION

SYMPTOM	POSSIBLE CAUSE
Unit won't cool	Clogged fins on coil(s)
	Dirty filter
	Impellers not running
	Compressor not running
	Compressor runs, but has bad valves
	Loss of refrigerant
Compressor tries to start but won't run	Low line voltage at start. Should be +/-10% rated voltage.
	Compressor motor stuck
	Bad contactor
	Bad overload switch
	Bad run/start capacitor
Unit blows breakers	Undersized breaker/fuse or not time delayed
	Short in system
Getting water in enclosure	Drain plugged
	Drain tube kinked
	Enclosure not sealed (allowing humidity in)
	Mounting gasket damaged

For additional technical support, contact nVent Equipment Protection at 800-896-2665.

BASIC AIR CONDITIONING TROUBLE SHOOTING CHECK LIST - REMOTE ACCESS CONTROL VERSION

1. Check manufacturer's nameplate located on the unit for correct power supply.
2. Turn on power to the unit. The controller will display a start up sequence then revert to the normal temperature display mode. Is the correct enclosure temperature displayed?

Note: The temperature may be alternating with an alarm code.

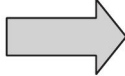
YES, proceed to step 3.		
NO, possible problem:		
<ul style="list-style-type: none"> » Open controller fuse » Controller in alarm condition. See Alarm Condition Display on page 14. » Defective controller » Defective thermistor - check by blowing warm air across the thermistor. If display temperature rises, thermistor is operable. 		<div style="background-color: black; color: white; padding: 5px; display: inline-block;">Replace part</div>

3. The cooling status indication (symbol G) should be on. Is the symbol on? If not, press and hold the lower right "snowflake" button for greater than five seconds. Is the cooling mode symbol now on?

YES, proceed to step 4.		
NO, possible problem:		
<ul style="list-style-type: none"> » Defective controller 		<div style="background-color: black; color: white; padding: 5px; display: inline-block;">Replace part</div>

4. The evaporator (Enclosure or "COLD" air) fan/impeller should turn on. Is there airflow?

YES, proceed to step 5.		
NO, possible problem:		
<ul style="list-style-type: none"> » Controller in alarm condition. See Alarm Condition Display on page 14. » Open motor winding » Stuck fan/impeller » Obstructed blades/wheel » Defective motor capacitor 		<div style="background-color: black; color: white; padding: 5px; display: inline-block;">Repair or Replace defective part</div>

5. Start the cooling cycle by changing the cooling setpoint parameter (r01) to the low limit of 72 F (22 C). Symbol 1 should be displayed indicating a call for cooling. If symbol 1 is flashing, the unit is in Restart Time Delay mode. Within 6 minutes, symbol 1 should display without flashing. Is symbol 1 displayed without flashing?

YES, proceed to step 8.		
NO, possible problem:		
<ul style="list-style-type: none"> » Unit still in Recycle Time Delay mode » Enclosure temperature below cooling setpoint temperature 		<div style="background-color: black; color: white; padding: 5px; display: inline-block;">Wait and/or heat enclosure thermistor T1</div>

6. The compressor and the condenser (Ambient or "HOT" air) impeller(s) should turn on. Is there adequate airflow?

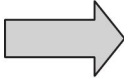
YES, proceed to step 7.		
NO, possible problem:		
» Open motor winding(s)		Repair or Replace defective part
» Stuck impeller(s)		
» Obstructed wheel(s)		
» Defective motor capacitor(s)		

7. Carefully check the compressor for proper operation - motor should cause slight vibration and the outer case of the compressor should be warm. Is the compressor showing signs of this?

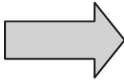
YES, wait 5 minutes, proceed to step 8.		
NO, possible problem:		
» Defective start or run capacitor		Repair or Replace defective part
» Defective overload		
» Defective start relay		
» Defective contactor		
» Defective compressor		

8. Make sure the coils are clean then check the evaporator "air in" and "air out" temperatures. If the temperatures are the same:

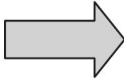
» Possible loss of refrigerant		Repair or Replace defective part
» Possible bad valves in compressor		

SYMPTOMS AND POSSIBLE CAUSES - REMOTE ACCESS CONTROL VERSION

SYMPTOM	POSSIBLE CAUSE
Unit won't cool	Clogged fins on coil(s)
	Dirty filter
	Impellers not running
	Compressor not running
	Compressor runs, but has bad valves
	Loss of refrigerant
Compressor tries to start but won't run	Low line voltage at start. Should be +/-10% rated voltage.
	Compressor motor stuck
	Bad contactor
	Bad overload switch
	Bad run/start capacitor
Unit blows breakers	Undersized breaker/fuse or not time delayed
	Short in system
Getting water in enclosure	Drain plugged
	Drain tube kinked
	Enclosure not sealed (allowing humidity in)
	Mounting gasket damaged

For additional technical support, contact nVent Equipment Protection at 800-896-2665.



nVent
2100 Hoffman Way
Anoka, MN 55303 USA
☎ +1.763.422.2211
📠 +1.763.576.3200

nVent.com